



THE XHS-300 SERIES

Operating and Service Manual

Series includes all variants of XHS-300/301/310/311 and XHM-300

Issue C
July 2013



TABLE OF CONTENTS

1. Description	3
2. Installation and Wiring	4
2.1 Enclosure (Junction Box)	4
2.2 Regulator	4
2.3 Manifold	4
2.4 Wiring Instructions	4
3. Operation	5
3.1 Adjusting the Regulator	5
3.2 Adjusting the Temperature	5
4. Special Conditions for Safe Use	5
5. Hazardous Location Usage	6
5.1 Marking	6
6. Servicing and Maintenance	6
6.1. Servicing the XHS-300 (SE option / Std. MVA)	7
6.1.1. Accessing the Main Valve Assembly	7
6.1.2. Figure 1 – Sectional View of the XHS-300 SE Option	8
6.2. Servicing the XHS-311 (IL option / Solid Disk MVA)	9
6.2.1. Accessing the Main Valve Assembly	9
6.2.2. Adjusting the Set Point	10
6.2.3. Figure 2 – Sectional View of the XHS-311 IL Option	11
7. Technical Data	12
7.1 Vibration Limits	12
7.2 Electronics	12
7.3 Heater	12
7.4 Mechanical Regulator	12
8. Warranty Statement	12

1. Description

There are three main types of single heated regulator which can be divided into the following groups:

- XHS-300/310 – Single heated, diaphragm sensed pressure regulator.
- XHS-301/311 – Single heated, piston sensed regulator.
- XHM-300 – Single heated manifold unit.

The XHS-300/301 regulators are capable of a maximum 300 bar inlet pressure (210 bar when fitted with the standard PCTFE seat). The maximum inlet pressure increases to 414 bar on the XHS-310 and XHS-311 options. The maximum control range of the XHS-300 and XHS-301 are 0-35 bar and 0-150 bar respectively.

The XHM-300 is an electronically heated manifold intended for altering the temperature of a flowing media.

Regulator housings and Manifold blocks are machined from 316 SS (stainless steel). This ensures maximum protection against the media on which they will be used and the environment in which they will be placed.

The electronics controlling the heat input to the regulator/manifold are installed within a Cooper Crouse Hinds flameproof enclosure (EABT-16). The electrical housing is of Aluminium Alloy construction, with mounting lugs to provide a secure connection to the panel. The user must ensure that media in contact with the regulator is compatible with these materials.

The enclosure has three ½”NPT entries through which the electrical supply can be made (ref. ‘Wiring Instructions’). The remaining entry must be sealed with an ATEX approved ½”NPT Blanking Plug.

The XHS-300 models are fitted with a single heater sheath enclosing a 100W cartridge heater within. A thermal fuse with an 85°C limit (+/- 2°C) is placed near the base of the cartridge to protect the regulators from exceeding their T3 temperature rating. This fuse is non-resettable.

The XHM-300 uses a 150W cartridge which is housed into the manifold block. The manifold incorporates a thermal fuse with a limit of 187°C limit (+/- 2°C) to protect the manifold from exceeding its T3 temperature rating. This fuse is non-resettable.

The XHS and XHM should not be exposed to any vibrations or impacts, and should be securely fastened in accordance to the Installation Instructions below, and should be limited to the vibration limits stated in the Technical Section.

Any pressure gauges used on the regulator must be designed as ‘Full Safety Pattern’ to BS1780, ANSI B40-1 and EN837-1.

2. Installation and Wiring

Before installation, check the nameplate (where applicable) and model number reference and ensure that the voltage type and pressure range complies with the installation requirements.

*Note: The installation of the XHS-300 and XHM-300 should be in accordance with EN 60079-14

2.1 Enclosure (Junction Box)

The whole assembly should be securely fastened to a back plate or panel using the corner holes in the junction box. For added support, the top of the regulator can be panel mounted around the bonnet, using the optional panel nut (PT C 024).

*Note: The panel nut alone should not support the regulator, i.e. with the box left freestanding.

2.2 Regulator

The pressure regulator is supplied with 1/4" NPT connections for both the inlet and outlet ports. Some units are supplied with connections for gauges, and these are also 1/4" NPT connections. The maximum supply pressure to the regulator should not exceed the maximum pressure indicated on the regulator label. The pipe work and gauges should be sealed with the regulator using PTFE tape.

*Note: Pressure Tech do not recommend sealant compound for pipe work connections.

2.3 Manifold

The heated manifold is supplied with 1/4" NPT connections for both the inlet and outlet ports. The maximum supply pressure to the manifold should not exceed 300bar pressure. The pipe work should be sealed with the regulator using PTFE tape.

*Note: Pressure Tech do not recommend sealant compound for pipe work connections.

2.4 Wiring Instructions

Ensure that no electrical power is supplied during maintenance, installation or servicing this product. The power supply to the junction box will require a certified cable gland to be used. The connection for the cable gland on the box is 1/2"NPT.

*Note: Wiring should be made in accordance with BS7671 'Requirements for electrical installations'.

Feed the supply cable through the cable gland (not supplied) and secure the wires to the terminal block ensuring the Live and Neutral are correctly orientated (ref. Drawing No. PT-XHS-300-201 / PT-XHS-300-202)

3. Operation

3.1 Adjusting the Regulator

For the XHS-300 series of regulators, turning the hand wheel clockwise compresses the spring, which in turn opens the main valve and allows the inlet pressure to pass through the orifice until the outlet pressure is equivalent to the loading forces set by the compressed spring.

3.2 Adjusting the Temperature

An adjustable potentiometer on the surface of the potted PCB board controls the amount of heat output via a burst firing controller. The cartridge is fitted with a type J sensor which monitors the temperature to the unit. Should this sensor fail, or the wiring becomes disconnected, the PCB will not apply power to the heater cartridge.

The adjustable pot is factory pre-set to its midpoint, but may need adjusting to increase or decrease the heat requirements to the regulator/manifold. *This adjustment must be made when there is no risk of explosion from the outside environment.

To adjust the setting:

- i. Loosen the M4 grub screw and open the cover of the junction box (*See 4.).
- ii. Change the heater output by turning the pot on the circuit board clockwise to increase, and anti-clockwise to decrease.
- iii. Due to the response time of heat transfer and thermal coefficients, the control system will require about 5 to 10 minutes to stabilise. Therefore, it is recommended that the heater is switched on before allowing the media to pass through the regulator.
- iv. The following percentage turns around the potentiometer equate to an approximate temperature value for the heater cartridges:
 - 10% – 20°C
 - 25% – 60°C
 - 50% – 100°C
 - 75% – 140°C
 - 100% – 180°C
- v. When the correct temperature setting is made, screw back the box cover and secure grub screw.

4. Special Conditions for Safe Use

The Equipment shall not be energised without a regulator or manifold attached.

On non-venting regulators with pressure on the outlet, the hand wheel shall not be turned anti-clockwise, in this case, pressure shall be reduced by venting downstream of the regulator and turning the hand wheel simultaneously anti-clockwise.

An external earth or equipotential bond in accordance with the requirements of EN 60079-0 clause 15 shall be made via one of the mounting holes in the electronics base.

The junction box should never be opened whilst there is a flammable gas atmosphere present, or when there is a risk of explosion from the outside environment.

5. Hazardous Location Usage

The XHS-300 and XHM-300 have been certified to ATEX Directive 94/9/EC, Group II, Category 2 for use in Gas environments, where the maximum surface temperature of the regulator does not exceed 200°C (based on ambient temperature conditions of -40°C to +55°C), and is flameproof to EN 60079-0 and EN 60079-1.

5.1 Marking

The marking of the equipment shall include the following:

Ex II 2 G
Ex d IIC GB T3 Ta = -40°C to +55°C

6. Servicing and Maintenance

The XHS can be divided in to two types, 'In-line' denoted by an 'IL' and 'Side Entry' denoted by an 'SE'. Each can be fitted with one of two options of main valve assembly (MVA). Two examples of which are used in this section with an intent of covering most options available.

Servicing and maintenance work on the XHS-300 series should only be performed after fully reading and understanding the Operating and Servicing Manual. Due to the typical nature of the gases the regulator will be used on, the operator should not endanger himself/herself or others by working on this regulator without prior knowledge on the Health and Safety concerns relating to handling of technical gases. Any uncertainty should be clarified with Pressure Tech before working on the regulator.

Repairs to the regulator should be performed in accordance with BS EN 60079-17 and BS EN 60079-19 as applicable.

Pressure Tech Ltd recommends the use of Krytox GPL 205 during servicing.

*Note: Any failure within the electronics should result in the unit being returned to Pressure Tech for evaluation and repair.

Prior to commencing service, please ensure that:

- The equipment has been de-pressurised
- The load spring has been de-compressed by turning the hand wheel / adjusting screw fully anti-clockwise
- Applications involving toxic, flammable or corrosive media have been fully purged

6.1. Servicing the XHS-300 (SE option / Std. MVA)

*Note: fig 1 should be used as a reference for the following set of instructions

6.1.1. Accessing the Main Valve Assembly

To access the Main Valve Assembly (MVA):

- i. Remove the mechanical regulator unit from the electrical assembly by gripping the flats on the Heater Sheath (19) with an adjustable or 30mm open ended wrench and turning the Regulator Body (7) anti-clockwise
- ii. With the flats of the Regulator Body (7) secured in a vice, use a 47mm open ended wrench to loosen the Bonnet (3) from the body
- iii. Remove the Upper Spring Rest (5), 10mm Ball Bearing (4), Load Spring (6), Diaphragm Washer (12), Lower Spring Rest (11) and Diaphragm (13) from the assembly
- iv. The Seat Nut (14) can then be removed using a 12mm socket
- v. Remove the Main Valve (16, 17) and Main Valve Spring (18) from the assembly
- vi. Visually inspect the seat nut and soft seat (17) for damage under a microscope
- vii. Replace the Main Valve Spring (18) and Main Valve (16, 17) and place into the Regulator Body (7)
- viii. Replace Seat Nut (14) fitted with new 5x1 mm o-ring (15) taking care not to damage its sealing face against the tip of the valve
- ix. To ensure positive sealing, it is recommended that a new Diaphragm (13) is placed centrally into Regulator Body (7) ensuring that the outermost convolutions are facing towards the Bonnet (3)
- x. Replace the 21x1 mm o-ring (10) on the Lower Spring Rest (11), insert into the Diaphragm Washer (12) and place on top of the Diaphragm (13)
- xi. Place the Load Spring (6), Upper Spring Rest (5) and 10mm Ball Bearing (4) to the assembly
- xii. Screw the Bonnet (3) onto the assembly and using a torque wrench with a 47mm open ended attachment, tighten to 160Nm

It is recommended that all parts in the repair kits are used. Any defect parts removed during the service should be disposed of. Parts should be kept clean in line with media requirements.

Following re-assembly of the regulator, pressure tests should be made to both the inlet and outlet side of the regulator, to ensure there is no internal or external leakage across the regulator.

To ensure that the main valve assembly has been correctly and effectively installed it may be required to perform the appropriate seat leak test as per ANSI/FCI 70-2.

Should any assistance be required during a service please do not hesitate to contact the office.

6.1.2. Figure 1 – Sectional View of the XHS-300 SE Option

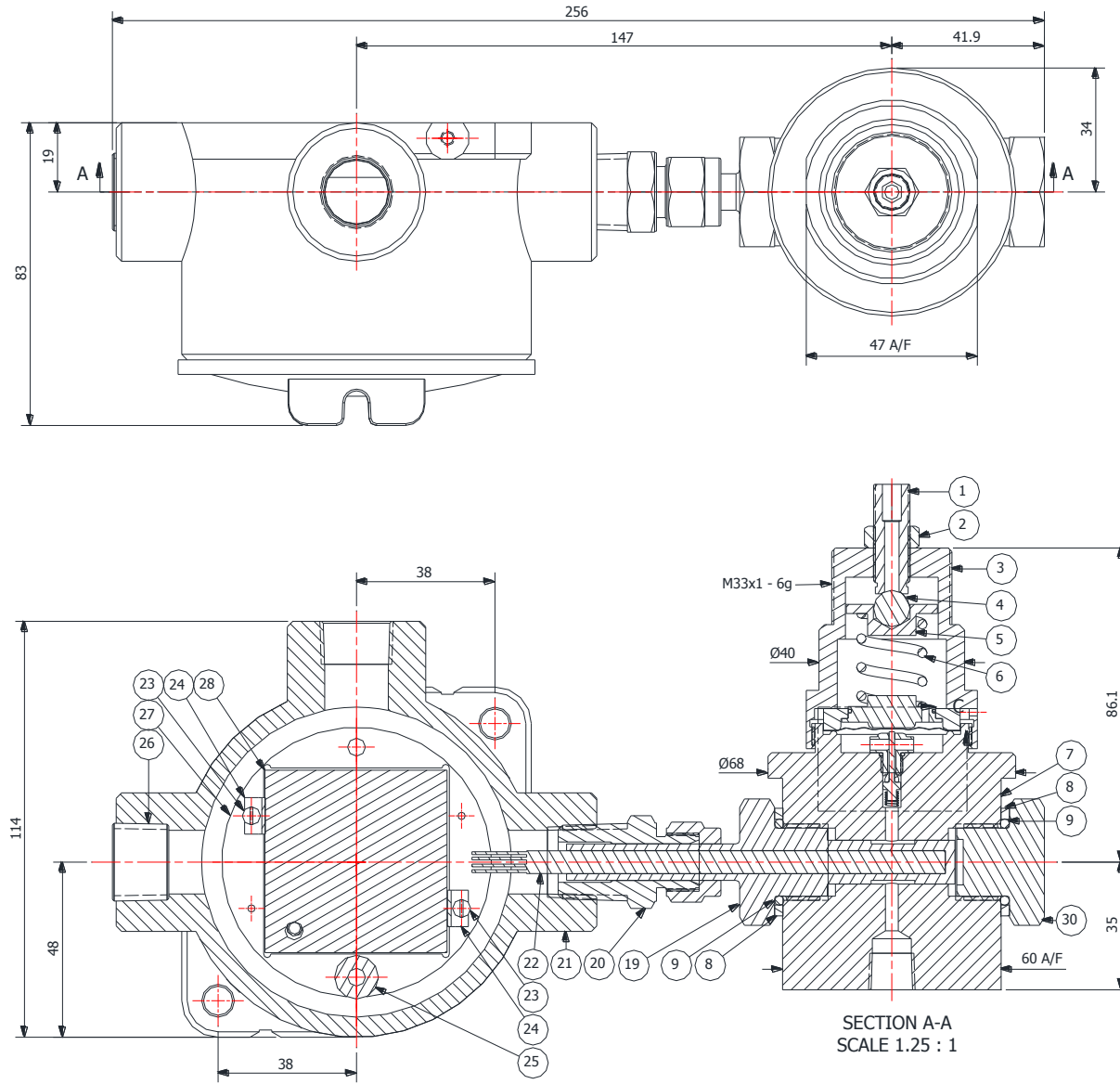

PARTS LIST		
ITE	PART NUMBER	DESCRIPTION
1	PT-C-062	ADJUSTING SCREW
2	PT-C-020	LOCKNUTS
3	PT-C-015	BONNET
4	BALL-010-SS-316	10MM BALL BEARING
5	PT-C-017	UPPER SPRING REST
6	PT-C-011-009	LOAD SPRING
7	PT-XHS-300-Z-SE ISS B	BODY
8	PT-XHS-300-009	1/2" BSP O' RING RETAINER
9	OR-BS116	O' RING STD
10	OR-0210-10	O' RING STD
11	PT-C-018-002	BOTTOM SPRING REST
12	PT-C-016	DIAPHRAGM WASHER
13	PT-C-010-002	DIAPHRAGM
14	PT-C-007-002	SEAT Cv 0.06
15	OR-0050-10	O' RING STD
16	PT-C-001-013	MAIN VALVE WITH SQUARE
17	PT-C-002-010	PEEK SEAT
18	PT-C-006-002	MV COMPRESSION SPRING
19	PT-XHS-300-005	HEATER SHEATH
20	PT-XHS-300-010-001	XHS FITTING
21	PT-XHS-300-011	ELEC BOX
22	PT-EHR-300-016-120	ELECTRIC HEATER CARTRIDGE
23	FIT-M2.5X6-SS-A2-PANSCREW	M2.5 x 6mm PAN HEAD SCREW
24	PT-XHS-300-015	SPRING CLIP
25	PT-EHR-300-010-001	EARTH ADAPTOR
26	FIT-CBA4200C	1/2" NPT PLUG-ATEX/IECEX
27	PT-XHS-300-014	MOUNTING PLATE
28	PT-XHS-300-BOARD	CIRCUIT BOARD
29	FIT-M4-6-SS-A2-POZI-CSK	COUNTERSUNK POZI SCREW
30	PT-XHS-300-006	BLANKING PLUG

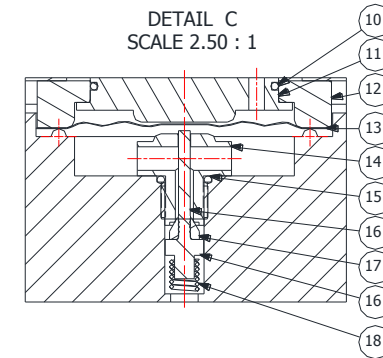

6.2. Servicing the XHS-311 (IL option / Solid Disk MVA)

*Note: fig 2 should be used as a reference for the following set of instructions

6.2.1. Accessing the Main Valve Assembly

To access the Main Valve Assembly (MVA):

- i. Remove the mechanical regulator unit from the electrical assembly by gripping the flats on the Heater Sheath (15) with an adjustable or 30mm open ended wrench and turning the Regulator Body (16) anti-clockwise
- ii. With the flats of the Regulator Body (16) secured in a vice, loosen the Bonnet (9) using a 47mm wrench ensuring that the Hand Wheel (3) is fully wound anti clock wise (1*)
- iii. Remove the Upper Spring Rest (7), 10mm Ball Bearing (6) and Load Spring (8) from the assembly
- iv. Lift the Lower Spring Rest (11) out of the assembly and then remove the sensor assembly comprising of Sensor (30) and Sensor Holder (12) from the Body (16)
- v. Using a 12mm socket, remove the Seat Retainer (32) and 9x1 mm o-ring (33) from the Body (16)
- vi. Grip the main valve (31) (needle nose pliers may be useful) and lift out of the Body (16) which will in turn bring out the Soft Seat Disk (35) and 6x1 mm o-ring (34)
- vii. The Main Valve Spring (36) can then be removed and replaced if required
- viii. Place new Main Valve (31) on to the Main valve Spring
- ix. The Soft Seat Disk (35) can then be positioned into the Body (16) ensuring that the o-ring groove is facing outwards then carefully position the 6x1 mm o-ring (33) into place (care should be taken when positioning the seat disk over the main valve)
- x. Replace the 9x1 mm o-ring (33) on the Seat Retainer (32) and screw the Seat Retainer into the Body (16) and tighten with a 12mm socket
- xi. Replace the 19x2 mm o-ring (14) and PT-C-176 Back Up ring (13) on the Sensor Holder (12) and replace the 8x2 mm o-ring (29) and PT-C-092-001 Back Up Rings (28) on the Sensor (30) - (BS008 and PT-C-104 for smaller 8mm sensor)
- xii. Place the Sensor (30) into the Sensor Holder (12) and position the assembly into the Regulator Body (16)
- xiii. Replace the 17.1x1.6 mm o-ring (10) on the Lower Spring Rest (11) and position into the Sensor Holder (12)
- xiv. Place the Load Spring (8), Upper Spring Rest (7) and 10mm Ball Bearing (6) to the assembly and screw the bonnet (9) into position
- xv. Finally tighten the bonnet to 90 Nm with a 47mm open ended torque wrench

It is recommended that all parts in the repair kits are used. Any defect parts removed during the service should be disposed of. Parts should be kept clean in line with media requirements. Following re-assembly of the regulator, pressure tests should be made to both the inlet and outlet side of the regulator, to ensure there is no internal or external leakage across the regulator.

Should any assistance be required during a service please do not hesitate to contact the office.

(1*) It is not recommended (or necessary) to remove the Hand Wheel (3) during service as this will affect the set point of the regulator. Should it be required to adjust the set point please follow the instructions below:

6.2.2. Adjusting the Set Point

To adjust the set point:

- i. Remove the Nameplate (1) and Cap (2) from the Hand Wheel (3) and loosen the Lock Nut (5) such that the Hand Wheel is able to spin freely on the Adjusting Screw (4)
- ii. Connect the correct fittings to the Inlet and Outlet ports of the regulator. Ensure that any gauge ports are plugged or that the correct gauge is fitted
- iii. With the Regulator Body (16) securely fixed to the Heater Sheath (15) apply the Maximum Working Pressure (MWP) to the Inlet of the regulator
- iv. Connect the Outlet port to a calibrated pressure test gauge appropriate to the required set pressure. As the regulator is non-venting, ensure that a ball/needle valve is fitted to allow pressure to be relieved downstream of the regulator
- v. Using a slotted screwdriver, turn the Adjusting Screw (4) clockwise until the desired set point has been reached
- vi. Ensure repeatability by allowing flow through the regulator using the ball/needle valve
- vii. With the outlet pressure set, screw the first Lock Nut (5) to the base of the Adjusting Screw (4) against the Bonnet (9)
- viii. Position the Hand Wheel (3) onto the Lock Nut (5). Ensure that the Lock Nut and Hand Wheel become engaged
- ix. Fasten the second Lock Nut (5) against the Hand Wheel (3) and gently begin to tighten using a 13mm socket until it begins to secure itself
- x. At this point, whilst holding the Hand Wheel (3) continue to tighten whilst simultaneously turning slightly anti-clockwise to prevent it from locking against the Bonnet (9)
- xi. Ensure that the Lock Nut (5) is sufficiently tightened, taking care not to adjust the set point
- xii. Turning of the Hand Wheel (3) should now also turn the Adjusting Screw (4) which will control the pressure
- xiii. Turn the Hand Wheel (3) clockwise until it reaches its set point and check to make sure that the desired outlet pressure is correct.
- xiv. If the set point is not correct, repeat steps v. to xiii.
- xv. Reduce the pressure downstream by venting the pressure through ball/needle valve and then turning the Hand Wheel (3) anti-clockwise until the regulator closes
- xvi. The Cap (2) and Nameplate (1) can now be placed into the Hand Wheel (3). Ensure that the information stated on the Nameplate (1) is in accordance with the set pressure of the regulator

6.2.3. Figure 2 – Sectional View of the XHS-311 IL Option

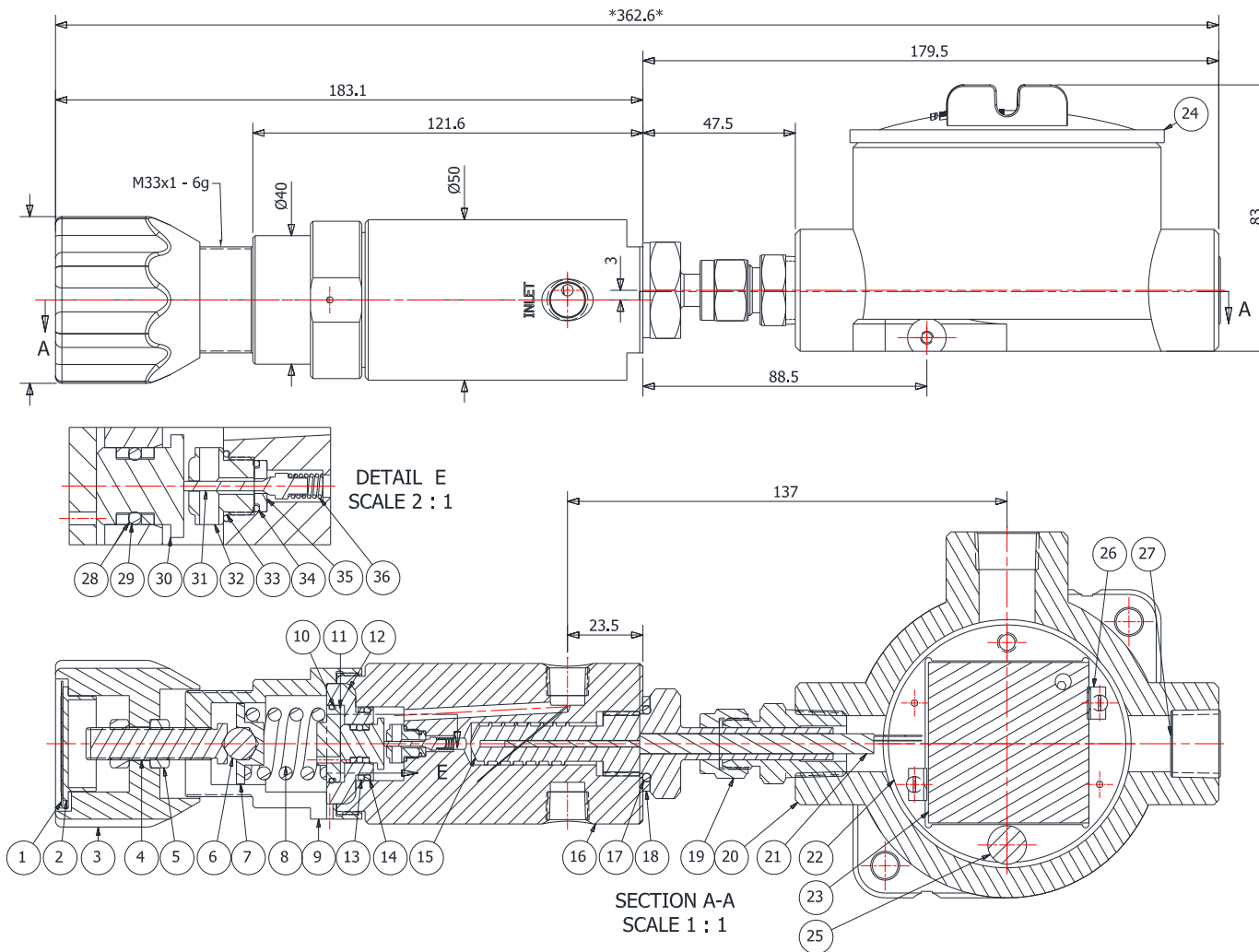

PARTS LIST		
ITE	PART NUMBER	DESCRIPTION
1	PT-C-022	NAMEPLATE
2	FIT-CAP-4343092	NAMEPLATE CAP
3	PT-C-021	SMALL HANDWHEEL
4	PT-C-019-003	ADJUSTING SCREW
5	PT-C-020	LOCKNUTS
6	BALL-010-SS-316	10MM BALL BEARING
7	PT-C-017	UPPER SPRING REST
8	PT-C-011-003	86KG LOAD SPRING
9	PT-C-015	BONNET
10	OR-0171-16	O' RING STD
11	PT-C-018-006	LOWER SPRING REST
12	PT-C-137	12MM SENSOR HOLDER
13	PT-C-176	PTFE BACK UP RING
14	OR-0190-20	O' RING STD
15	PT-XHS-300-001-002	HEATER SHEATH IL
16	PT-XHS-301-N-IL-002	BODY
17	OR-BS116	O' RING STD
18	PT-XHS-300-009	1/2" BSP O' RING RETAINER
19	PT-XHS-300-010	XHS FITTING (HAMLET 768 10 X 1/2)
20	ELEC- EABT-16	CROUSE HINDS BOX
21	PT-EHR-300-016-120	ELECTRIC HEATER CARTRIDGE
22	A4-PT-XHS-300-014	MOUNTING PLATE
23	PT-XHS-300-BOARD	CIRCUIT BOARD
24	EABT-16-1	CROUSE HINDS BOX - LID
25	PT-EHR-300-010-001	EARTH ADAPTOR
26	PT-XHS-300-015	SPRING CLIP
27	FIT-CBA4200C	1/2" NPT ATEX/IECEx PLUG
28	PT-C-092-001	PTFE BACK UP RING
29	OR-0080-20	O' RING STD
30	PT-C-138	12MM SENSOR
31	PT-C-001-023	MAIN VALVE - SOLID TYPE
32	PT-C-007-015	SEAT RETAINER
33	OR-0090-10	O' RING STD
34	OR-0060-10	O' RING STD
35	PT-C-198-001	PEEK 450 SEAT
36	PT-C-006-002	MAIN VALVE COMPRESSION SPRING
37*	FIT-M4X5-SS-A2-SKT-CSK	M4 X 5 COUNTERSUNK SCREW

© Copyright of Pressure Tech Ltd

7. Technical Data

7.1 Vibration Limits

This equipment can be used where vibration limits do not exceed 5m/s^2

7.2 Electronics

Supply Voltage:	115V or 230Vac (+/- 15% at 50Hz or 60Hz), 2 Amps max
Power Load:	100W (XHS-300), 150W (XHM-300)

7.3 Heater

Sensor Type:	Proportional Type J thermocouple with automatic CJC
Temp Control Range:	0°C to 180°C
Temp Control accuracy:	+/- 1%
Temp repeatability:	+/- 2%

7.4 Mechanical Regulator

Fluid Media:	All gases and liquids compatible with materials of construction
Max Inlet Pressure:	300 bar (XHS-300/301) 414 bar (XHS-310/311)
Outlet Pressure Range:	0-35 bar (XHS-300), 0-150 bar (XHS-301)
Materials:	Body and Trim: 316 SS Diaphragm: Inconel X750 Seat: PCTFE or PEEK® Enclosure: Aluminium
Flow Capacity (Cv):	0.06

8. Warranty Statement

Pressure Tech Ltd guarantee all products correspond with their specification at the time of delivery and, with exception to wear and tear, wilful damage, negligence, and abnormal working conditions, will be free from defects for a period of 12 months from date of delivery.